

SECTION A-A
SCALE 1 : 1

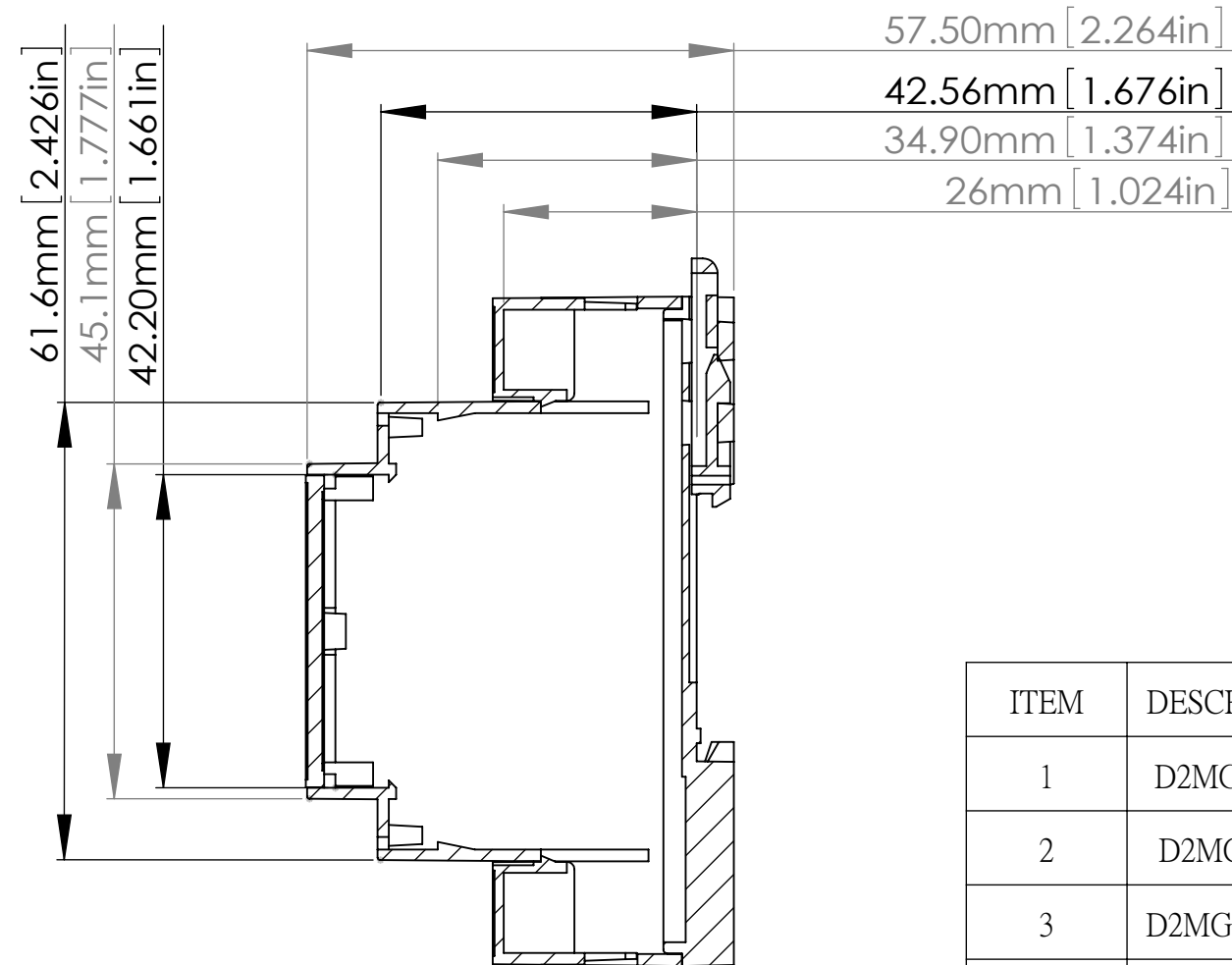

SECTION B-B
SCALE 1 : 1

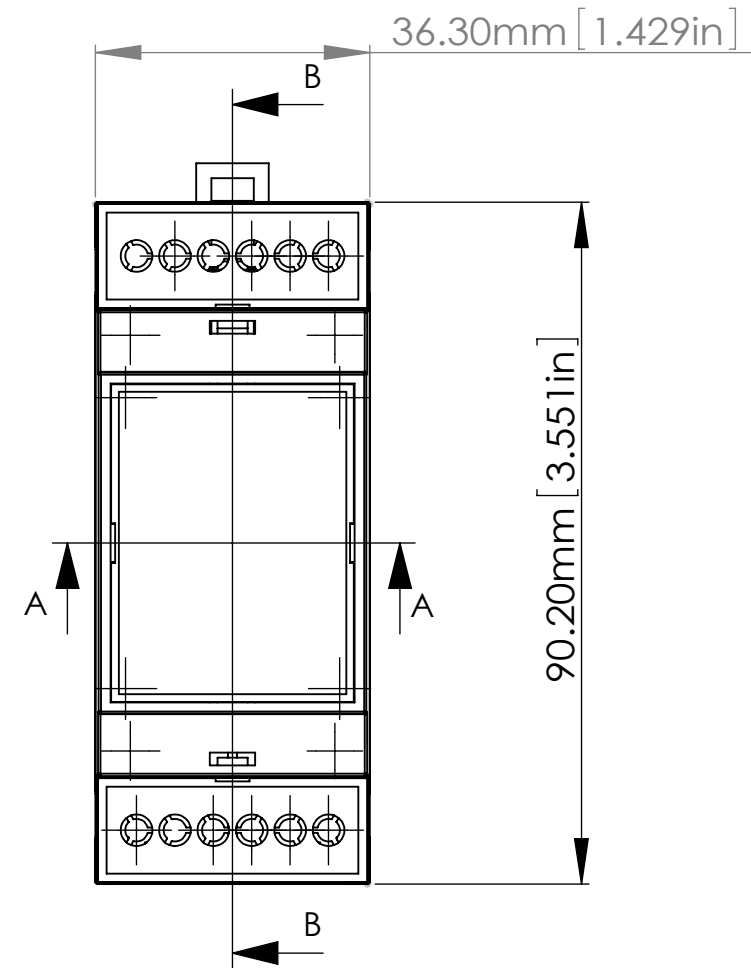
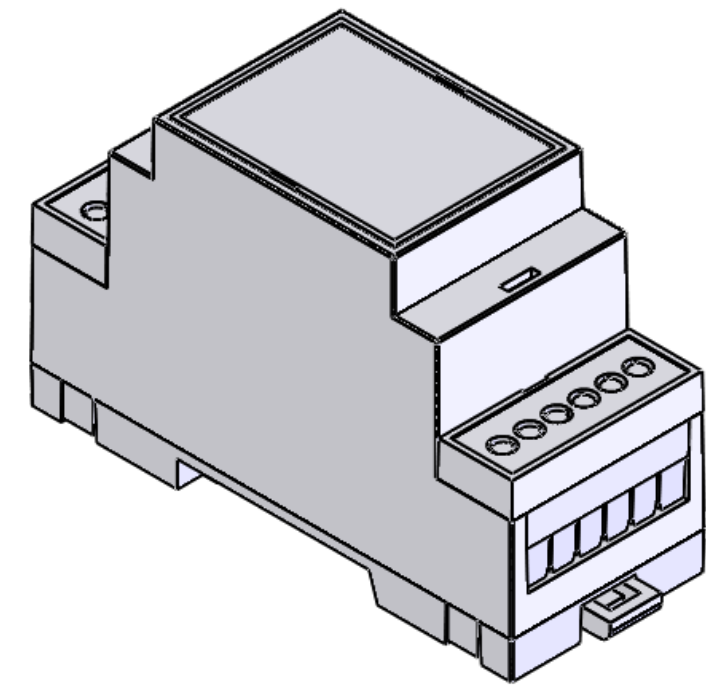

ASSEMBLY

ITEM	DESCRIPTION	MATERIAL	COLOUR	UNIT
1	D2MG-BODY	PC/ABS(UL94-V0)	GREY	1
2	D2MG-BASE	PC/ABS(UL94-V0)	GREY	1
3	D2MG-COVER	PC/ABS(UL94-V0)	GREY	1
4	D2MG-GUARD	PC/ABS(UL94-V0)	GREY	2
5	D2MG-WALL CLIP	NYLON66(UL94-V0)	DARK GREY	1

宣又實業有限公司
GAINTA INDUSTRIES LTD.

繪圖 DRA'D BY
JACKY

日期 DATE
2010/4/15

材質 MATE.
PC/ABS(UL94-V0);
NYLON66(UL94-V0)

圖名TITLE:
D2MG-ASSEMBLY

圖號DWG NO:

版次REVISID:
A

D2MG-BODY

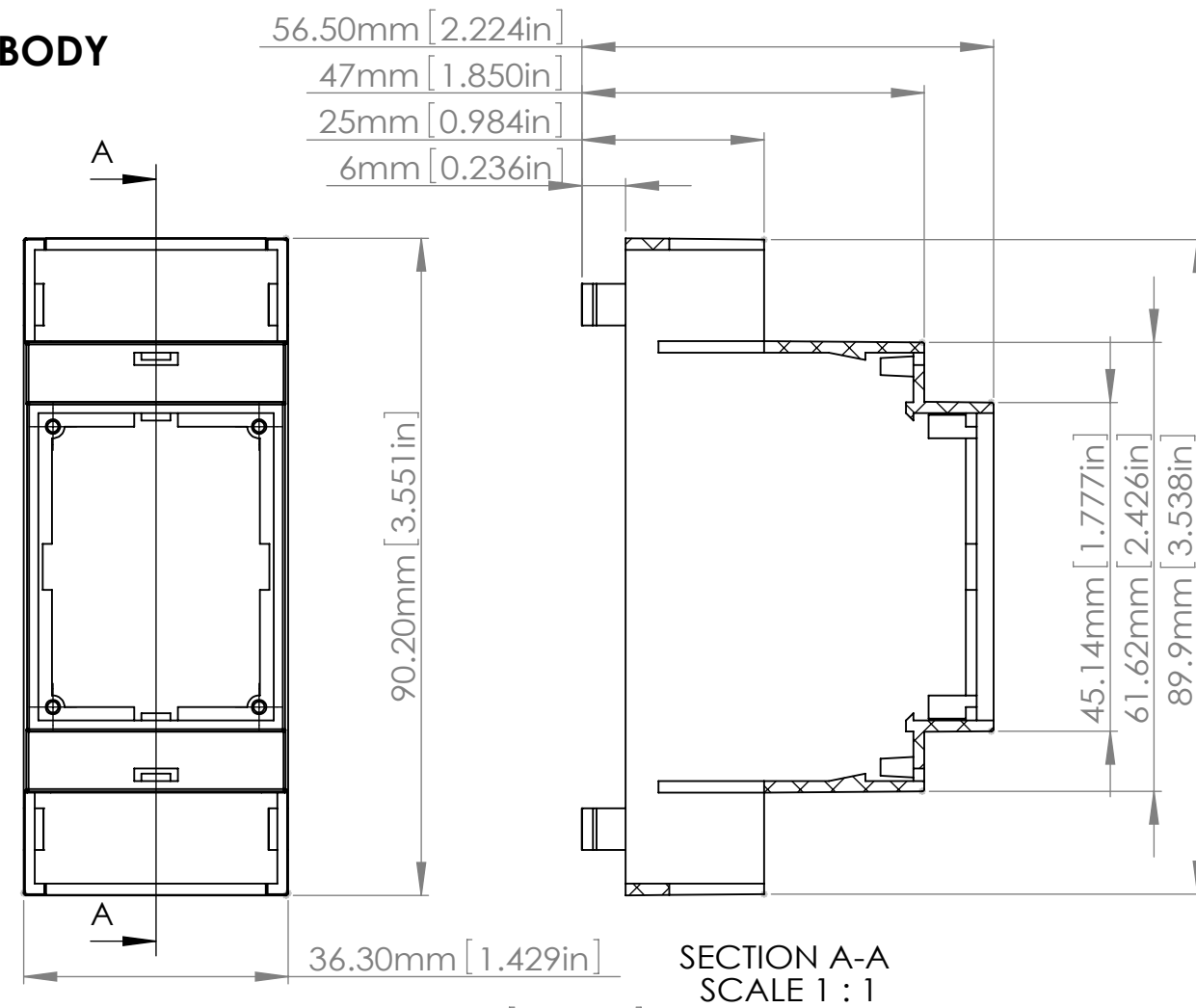

D2MG-BASE

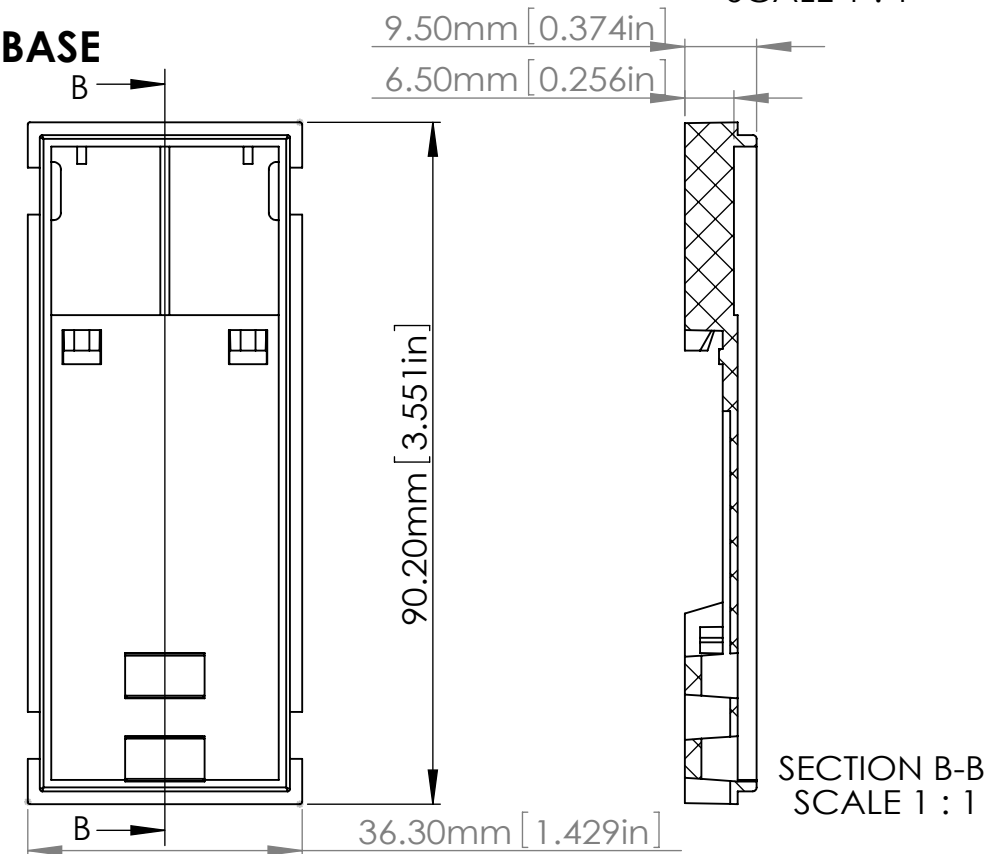

D2MG-COVER

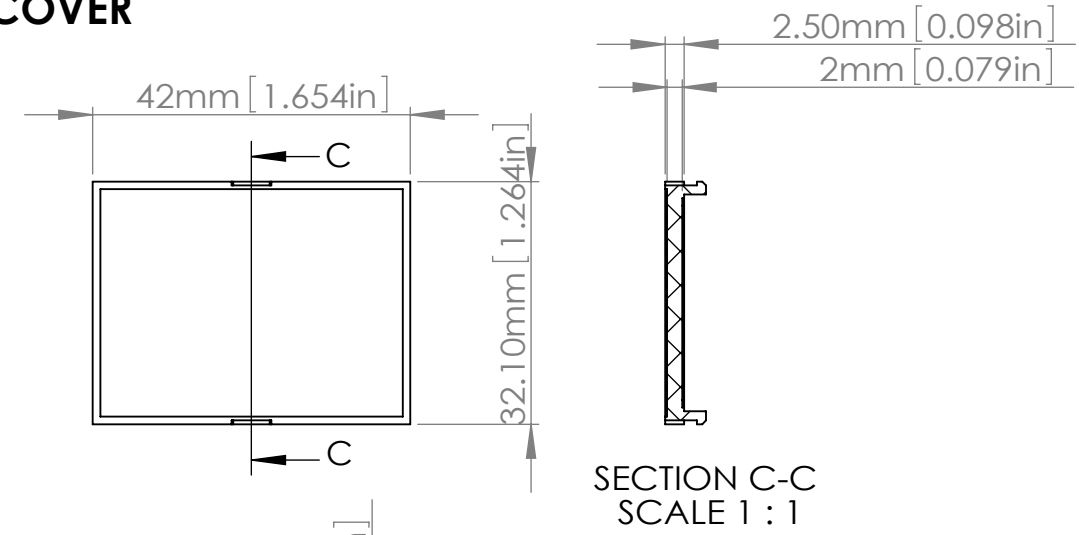

D2MG-GUARD

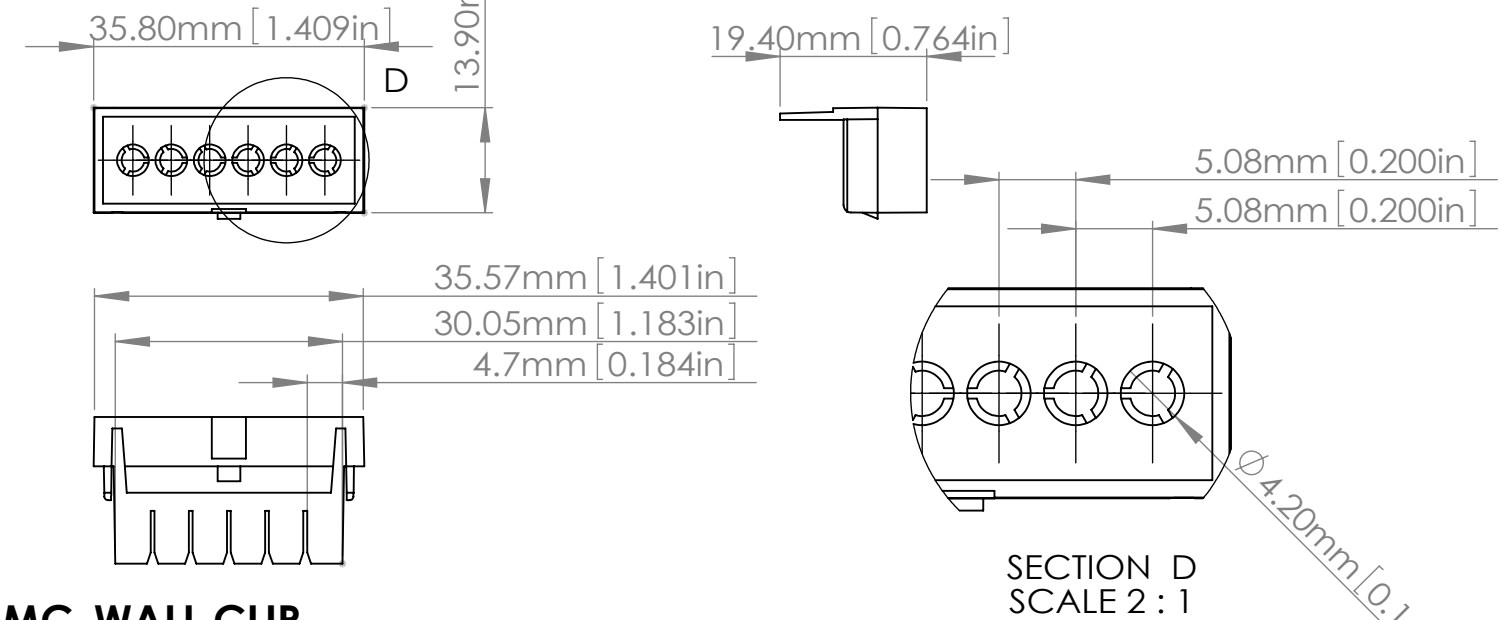

D2MG-WALL CLIP

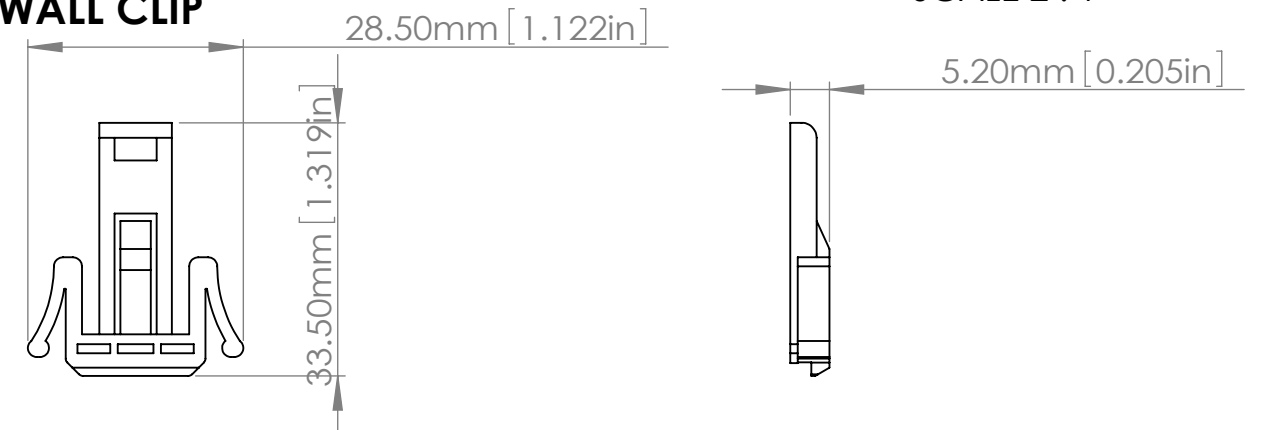

宣又實業有限公司
GAINTA INDUSTRIES LTD.

繪圖

DRA'D BY

JACKY

日期

DATE

2010/4/13

材質

MATE.

PC/ABS(UL94-V0);
NYLON66(UL94-V0)

圖名TITLE:

D2MG-PART

圖號DWG NO:

版次REVISID:

A